

NAVCO Floating Ball Valves

Dependability for upstream general-purpose valve applications

NAVCO H1L Ball Valves



Features and benefits

- One-piece carbon steel reduced-port screwed-end ball valve
- 316 stainless steel ball and stem
- Blowout-proof stem
- 2,000-psi water-oil-gas (WOG) pressure
- ¼ to 2 in [8 to 50 mm]
- 150-psi saturated steam
- Conformance to NACE MR0175/ISO 15156 specifications
- Locking handle

Materials List

Quantity	Part	Material
1	Body	A105
1	Seat retainer	A105
1	Ball	CF8M
2	Seat	Reinforced tetrafluoroethylene (RTFE)
1	Stem	AISI 316
2	Thrust washer	Reinforced polytetrafluoroethylene (RPTFE)
1	Stem packing	Polytetrafluoroethylene (PTFE)
1	Gland	AISI 304
1	Spring washer	AISI 304
1	Nut	AISI 304
1	Handle	Stainless steel (SS) 201
1	Handle sleeve	Vinyl
1	Gasket	PTFE

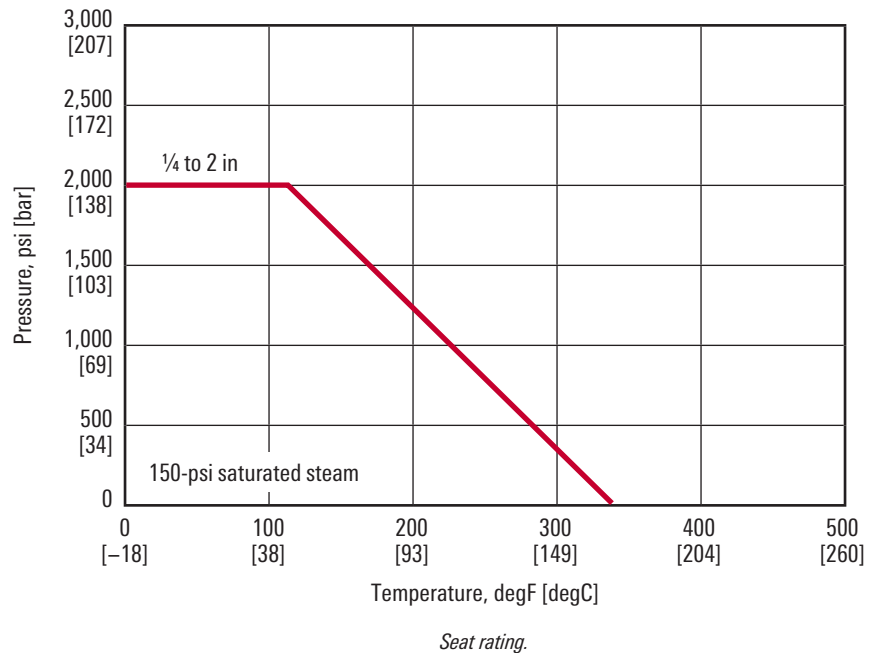

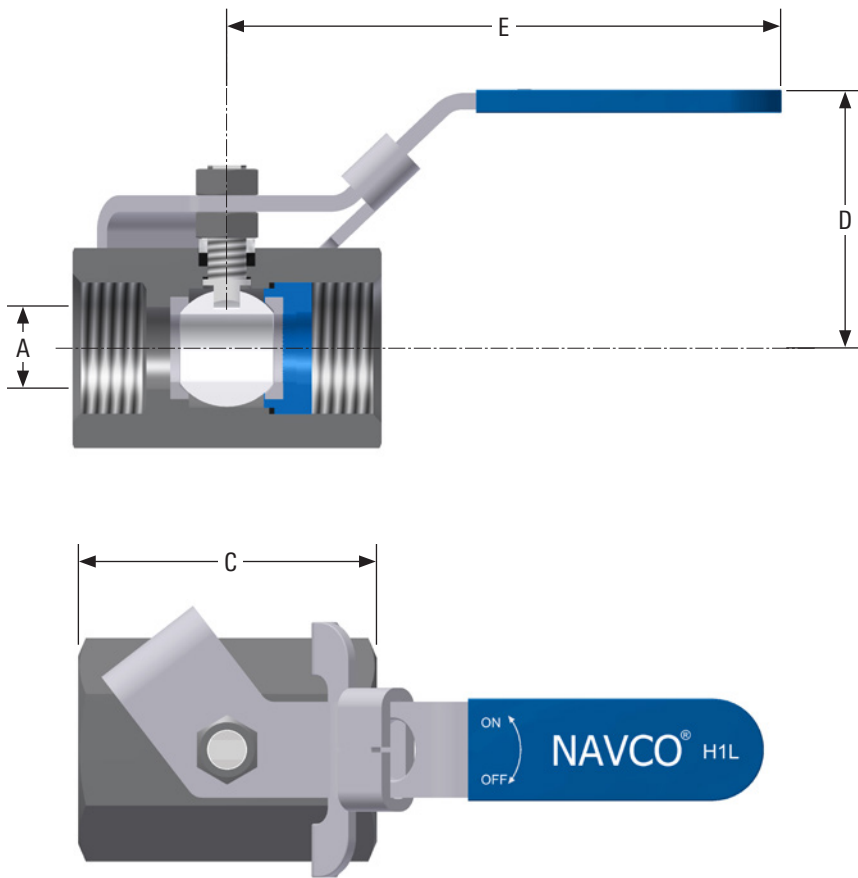

Dimensions

Size, in [mm]	A	C	D	E	C _v
¼ [8]	0.20 [5.0]	1.70 [43.1]	1.25 [31.8]	2.63 [66.7]	1.5
⅜ [10]	0.28 [7.0]	1.86 [47.2]	1.33 [33.8]	2.63 [66.7]	3.5
½ [15]	0.36 [9.2]	2.46 [62.5]	2.18 [55.4]	4.65 [118]	4.5
¾ [20]	0.49 [12.5]	2.75 [69.9]	2.32 [59.0]	4.65 [118]	8
1 [25]	0.63 [16.0]	3.38 [85.73]	2.57 [65.3]	4.72 [120]	15
1½ [40]	0.95 [24.1]	4.00 [101.6]	3.10 [78.7]	5.75 [146]	40
2 [50]	1.26 [32.0]	4.50 [114.3]	4.70 [119.4]	6.00 [152.4]	70

Data

Size, in	¼	⅜	½	¾	1	1½	2
Max. working pressure, psi	2,000	2,000	2,000	2,000	2,000	2,000	2,000
Weight, lbm	0.08	0.18	0.55	0.88	1.90	3.74	6.31

NAVCO C1 Ball Valve

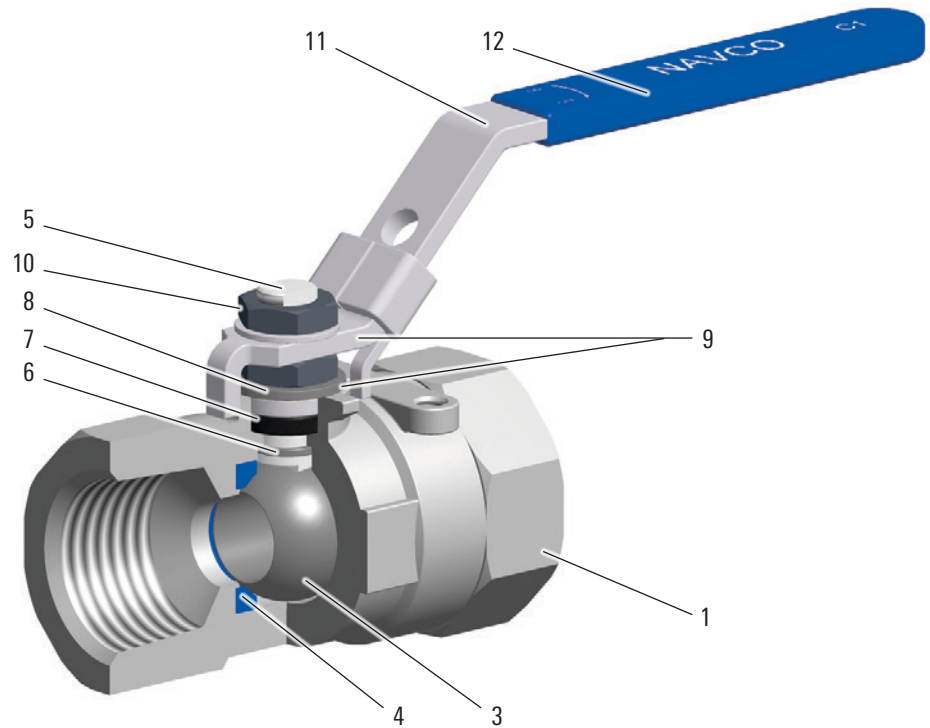

Features and benefits

- Investment cast body
- Fire testing and certification to API 607 5th Edition
- Conformance to NACE/ISO 15156
- Positively retained stem design
- Handle locking device
- Conformance to ASME B16.34
- Availability in carbon steel–stainless steel and stainless steel–stainless steel
- 2,000-psi maximum operating pressure (MOP)

Materials List

Item	Quantity	Part	Material
1	1	Body	WCB/CF8M
2	1	Cap†	WCB/CF8M
3	1	Ball	CF8M
4	2	Seat	PTFE
5	1	Steam	AISI 316
6	1	Steam seal	PTFE
7	1	Steam packing	Graphite
8	1	Gland	AISI 304
9	2	Washer	SS
10	2	Nut	A2-70
11	1	Handle	SS 201
12	1	Handle sleeve	PVC
13	1	Body gasket	Graphite

†Internal endcap not shown

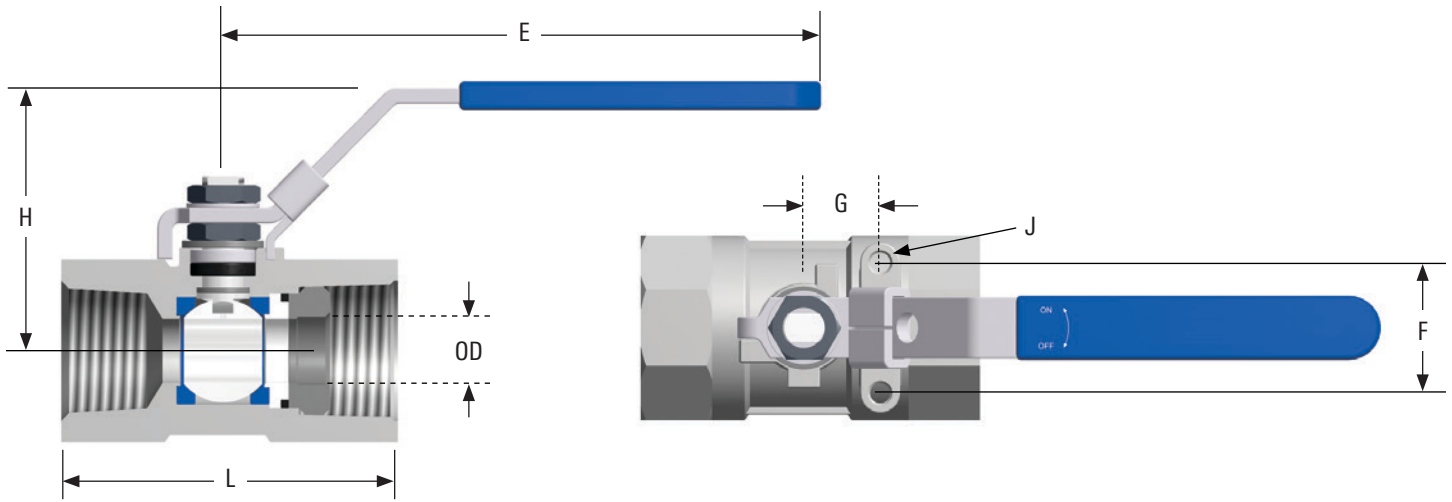

Dimensions

Size, in [mm]	OD	L	E	H	G	F	J
¼ [6.43]	0.36 [9.2]	2.32 [59]	4.37 [111]	1.73 [44]	0.50 [12.7]	1.12 [28.5]	10–24 UNC
⅜ [9.53]	0.36 [9.2]	2.32 [59]	4.37 [111]	1.73 [44]	0.50 [12.7]	1.12 [28.5]	10–24 UNC
½ [12.7]	0.36 [4.2]	2.64 [67]	4.37 [111]	1.73 [44]	0.50 [12.7]	1.12 [28.5]	10–24 UNC
¾ [19.1]	0.49 [12.5]	2.80 [71]	4.37 [111]	2.09 [53]	0.50 [12.7]	1.12 [28.5]	10–24 UNC
1 [25.4]	0.63 [16]	3.31 [84]	5.43 [138]	2.36 [60]	0.87 [22.1]	1.37 [34.8]	10–24 UNC
1½ [38.1]	1 [24.5]	3.94 [100]	6.69 [170]	2.80 [71]	0.93 [23.6]	1.50 [38.1]	¼ in–20 UNC
2 [50.8]	1.26 [32]	4.65 [118]	6.69 [170]	3.01 [76.5]	0.93 [23.6]	1.50 [38.1]	¼ in–20 UNC

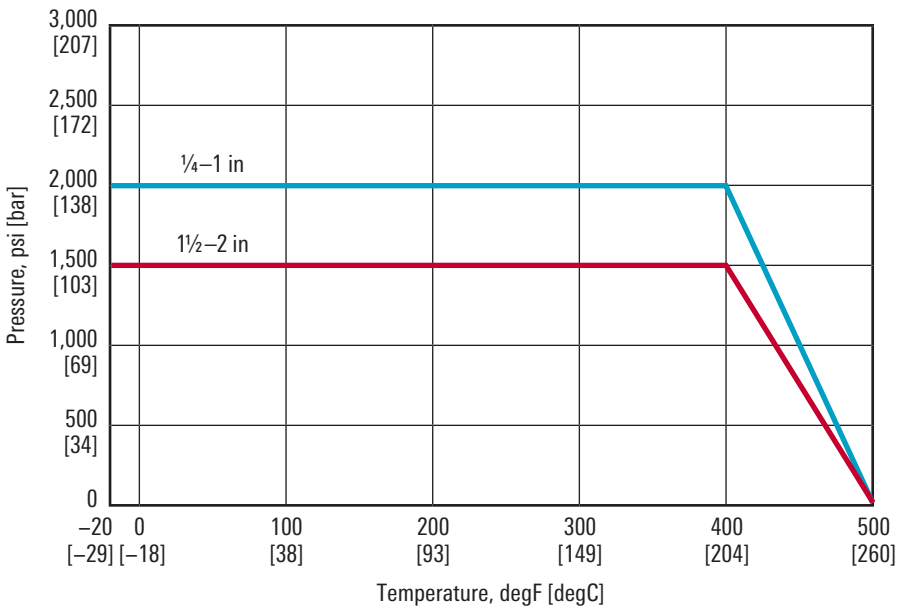

Seat rating.

NAVCO B3 Floating Ball Valve



Features and benefits

- Positively retained stem
- Adjustable packing
- 316 stainless steel ball and stem
- Standard locking handle
- Actuator mounting pad
- Delrin® material seats standard
- 3,000 psi, sizes ¼ to 2 in [8 to 50 mm], full port
- Ball that includes pressure equalization hole to prevent trapped pressure in body cavity (in open position only)
- Fire testing in accordance with API 607
- Conformance to NACE MR0175/ISO 15156 specifications

Materials List

Part	Material	
Body	WCB carbon steel (CS) or CF8M SS	
Seat	Delrin material	
Body O-ring	Viton® material	
Body gasket	Graphite	
Adapter	WCB CS/CF8M SS	
Ball	316 SS	
Stem thrust washer	Delrin material	
Stem packing	Graphite	
Packing gland	304 SS	
Stem	316 SS	
Stem nut	A2-70	
Handle	¼ to 1 in	SS 201
	1¼ to 2 in	CS
Locking device	¼ to 1 in	SS 201
	1¼ to 2 in	CS
Handle grip	PVC	
Stop capscrew	A2-70	
Capscrew	SS 201	

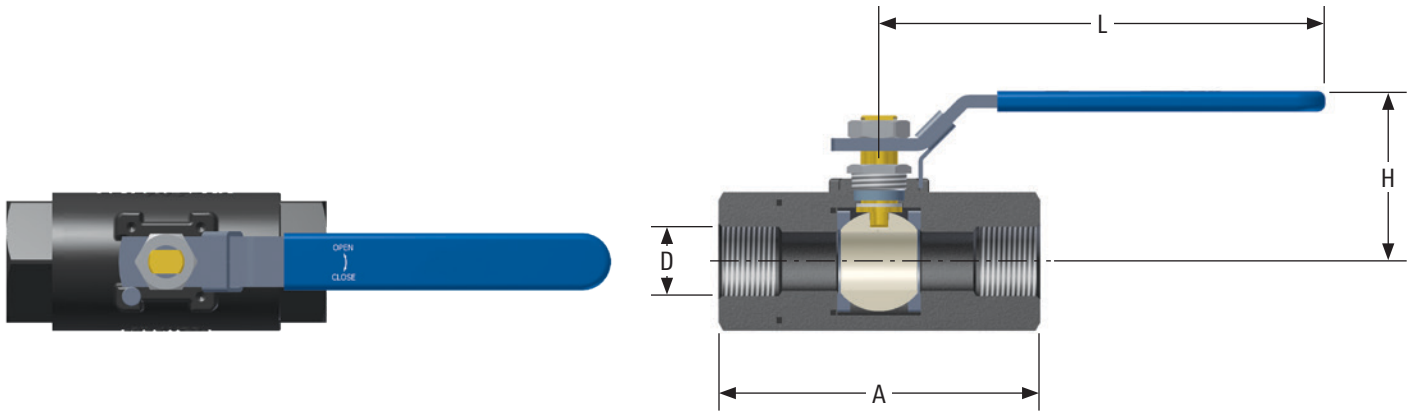

Two-piece WCB and CF8M body screwed-end ball valve.

Dimensions

Size, in [mm]	D Port Size, F × F	A End-to-End, F × F	L Length of Lever	H Center to Lever	C _v
¼ [8]	0.39 [10]	3.86 [98]	5.71 [145]	2.32 [59]	8
⅜ [10]	0.39 [10]	3.86 [98]	5.71 [145]	2.32 [59]	8
½ [15]	0.50 [13]	3.86 [98]	5.71 [145]	2.32 [59]	15
¾ [20]	0.75 [19]	4.25 [108]	7.48 [190]	2.61 [66]	30
1 [25]	0.98 [25]	5.39 [137]	7.48 [190]	2.85 [72]	60
1½ [40]	1.50 [38]	6.30 [160]	10.04 [255]	5.16 [131]	130
2 [50]	1.89 [48]	6.30 [160]	16.14 [410]	5.42 [138]	290

Data

Size, in	¼	⅜	½	¾	1	1½	2
Max. cold working pressure (CWP), psi	3,000	3,000	3,000	3,000	3,000	3,000	3,000
Weight, lbm	1.9	1.9	1.95	3.54	5.21	11.81	15.93
Assembly number (carbon steel–stainless steel)	83025-1217219B3	83038-1217219B3	83050-1217219B3	83075-1217219B3	83100-1217219B3	83150-1217219B3	83200-1217219B3
Assembly number (stainless steel–stainless steel)	83025-2217219B3	83038-2217219B3	83050-2217219B3	83075-2217219B3	83100-2217219B3	83150-2217219B3	83200-2217219B3

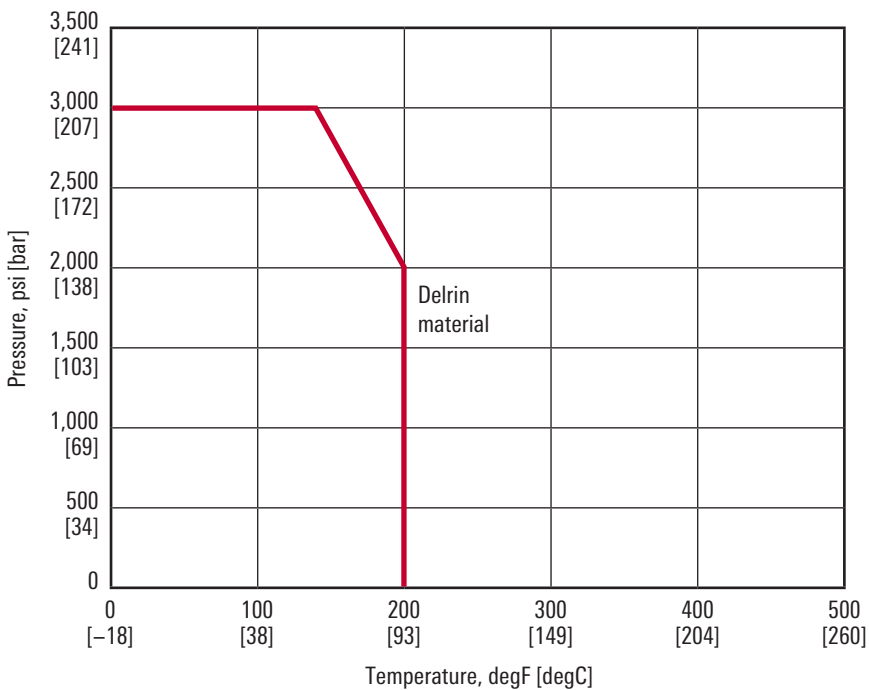

Engineering specifications.

NAVCO B6 Floating Ball Valve

Two-piece threaded-end ball valves

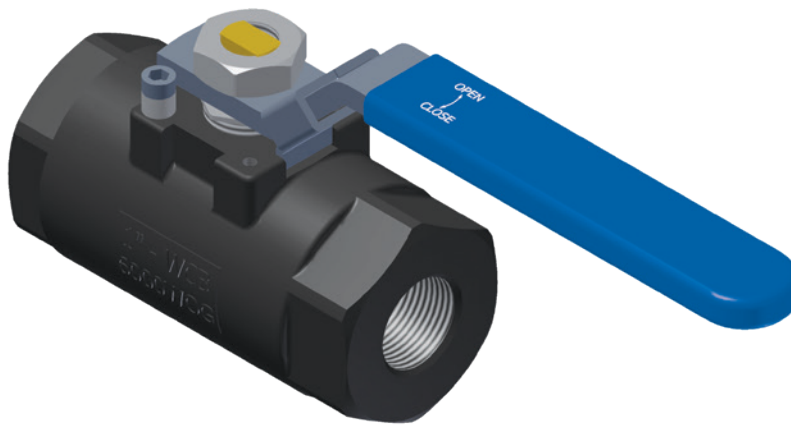

Features and benefits

- Positively retained stem
- Adjustable packing
- 316 stainless steel ball and stem
- Standard locking handle
- Actuator mounting pad
- PEEK seats standard
- 6,000 psi, sizes ¼ to 1½ in [8 to 40 mm], full port
- 6,000 psi, size 2 in [50 mm], reduced port
- Fire testing in accordance with API 607
- Conformance to NACE MR0175/ISO 15156 specifications

Materials List

Part	Material	
Body	WCB CS/CF8M SS	
Seat	PEEK	
Body O-ring	Viton material	
Body gasket	Graphite	
Adapter	WCB CS/CF8M SS	
Ball	316 SS	
Stem thrust washer	PEEK	
Stem packing	Graphite	
Packing gland	304 SS	
Stem	316 SS	
Stem nut	A2-70	
Handle	¼ to 1 in	SS 201
	1¼ to 2 in	CS
Locking device	¼ to 1 in	SS 201
	1¼ to 2 in	CS
Handle grip	PVC	
Stop capscrew	A2-70	
Capscrew	SS 201	

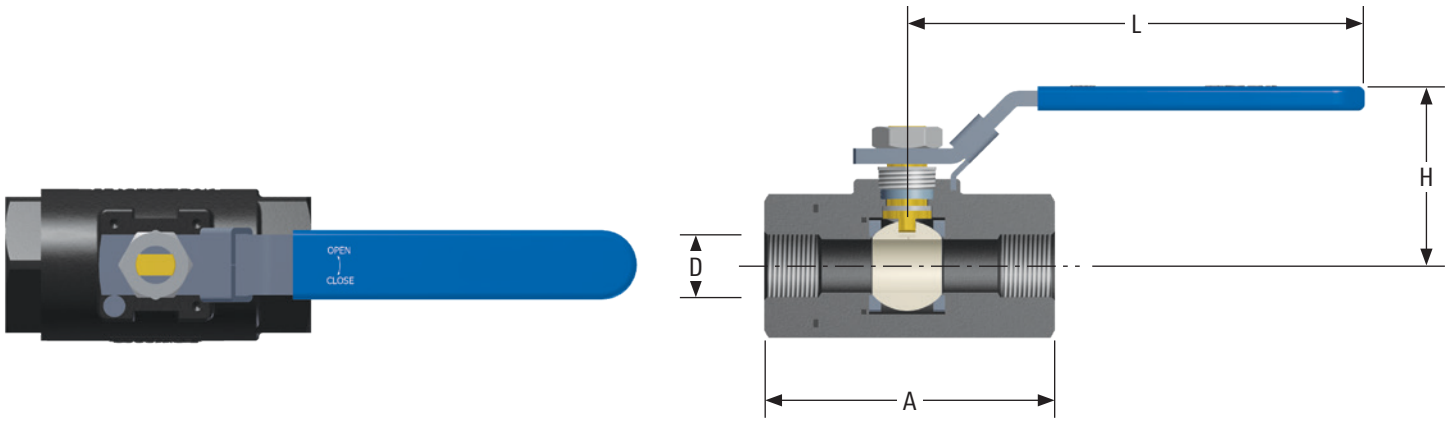

Two-piece WCB and CF8M body screwed-end ball valve.

Dimensions

Size, in [mm]	D Port Size, F × F	A End-to-End, F × F	L Length of Lever	H Center to Lever	C _v
¼ [8]	0.39 [10]	4.37 [111]	5.71 [145]	2.44 [62]	8
⅜ [10]	0.39 [10]	4.37 [111]	5.71 [145]	2.44 [62]	8
½ [15]	0.50 [13]	4.37 [111]	5.71 [145]	2.44 [62]	15
¾ [20]	0.75 [19]	4.37 [111]	7.48 [190]	2.72 [69]	30
1 [25]	0.98 [25]	5.39 [137]	10.04 [255]	3.58 [91]	60
1½ [40]	1.50 [38]	6.30 [160]	16.14 [410]	5.24 [133]	130
2 [50]	1.50 [38]	6.30 [160]	16.14 [410]	5.34 [136]	120

Data

Size, in	¼	⅜	½	¾	1	1½	2
Max. CWP, psi	6,000	6,000	6,000	6,000	6,000	6,000	6,000
Weight, lbm	2.20	2.20	2.20	4.43	8.12	19.93	20.28
Assembly number (carbon steel–stainless steel)	86025-1215219B6	86038-1215219B6	86050-1215219B6	86075-1215219B6	86100-1215219B6	86150-1215219B6	86200-1215219B6
Assembly number (stainless steel–stainless steel)	86025-2215219B6	86038-2215219B6	86050-2215219B6	86075-2215219B6	86100-2215219B6	86150-2215219B6	86200-2215219B6

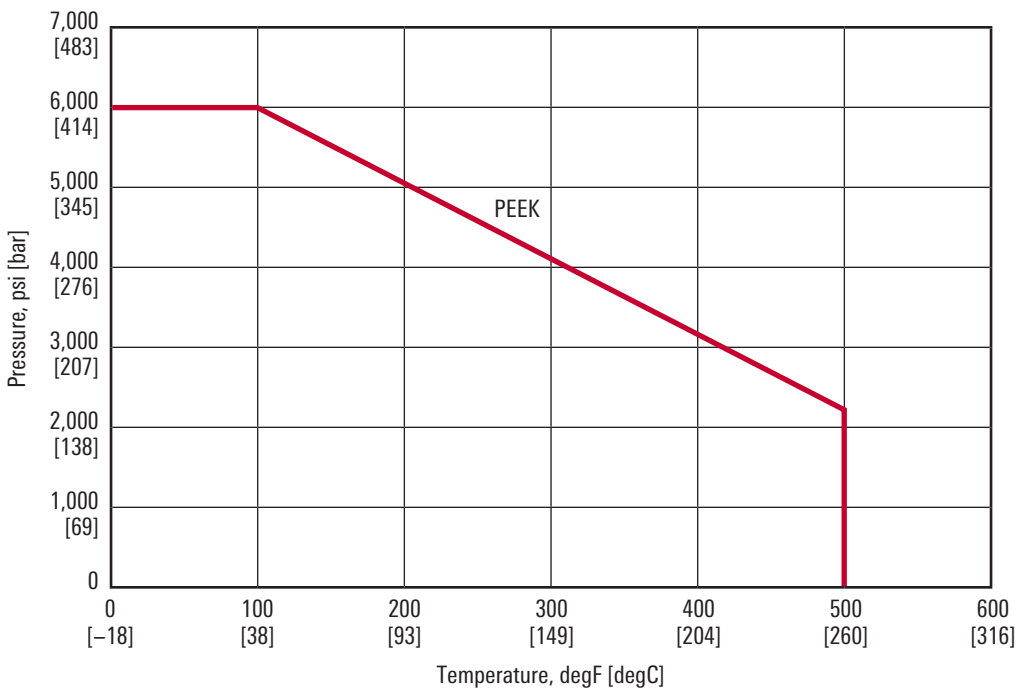

Engineering specifications.

NAVCO S10 Ball Valve

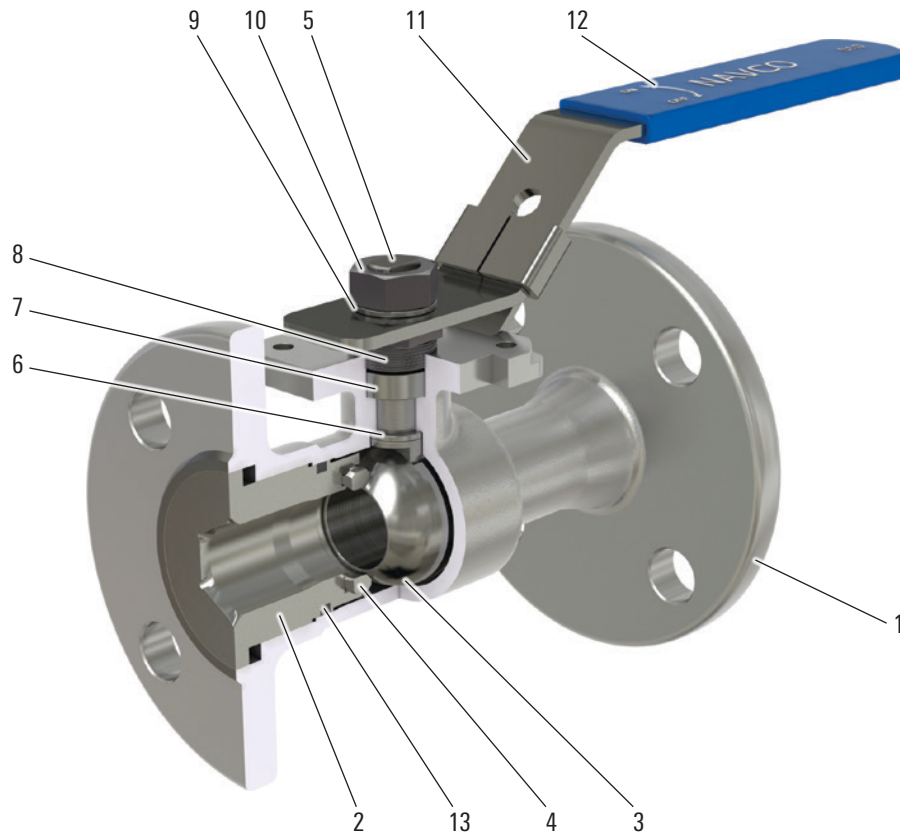

Features and benefits

- One-piece flanged-end ball valve, reduced port
- Investment cast body
- Fire testing and certification to API 607 5th Edition
- Working pressure:
ASME Class 150/300 specifications
- Conformance to NACE/ISO 15156
- Positively retained stem design
- Handle locking device
- ASME B16.34
- ISO mounting pad
- Availability in carbon steel–stainless steel and stainless steel–stainless steel
- Optional locking oval handle

Materials List

Item	Quantity	Part	Material
1	1	Body	WCB/CF8M
2	1	Cap	WCB/CF8M
3	1	Ball	CF8M
4	2	Seat	TFM
5	1	Stem	AISI 316
6	2	Thrust washer	RPTFE
7	1	Stem packing	PTFE
8	1	Gland	AISI 304
9	1	Lock washer	AISI 304
10	1	Nut	A2-70
11	1	Handle	AISI 304
12	1	Handle sleeve	PVC
13	1	Joint gasket	Graphite/304

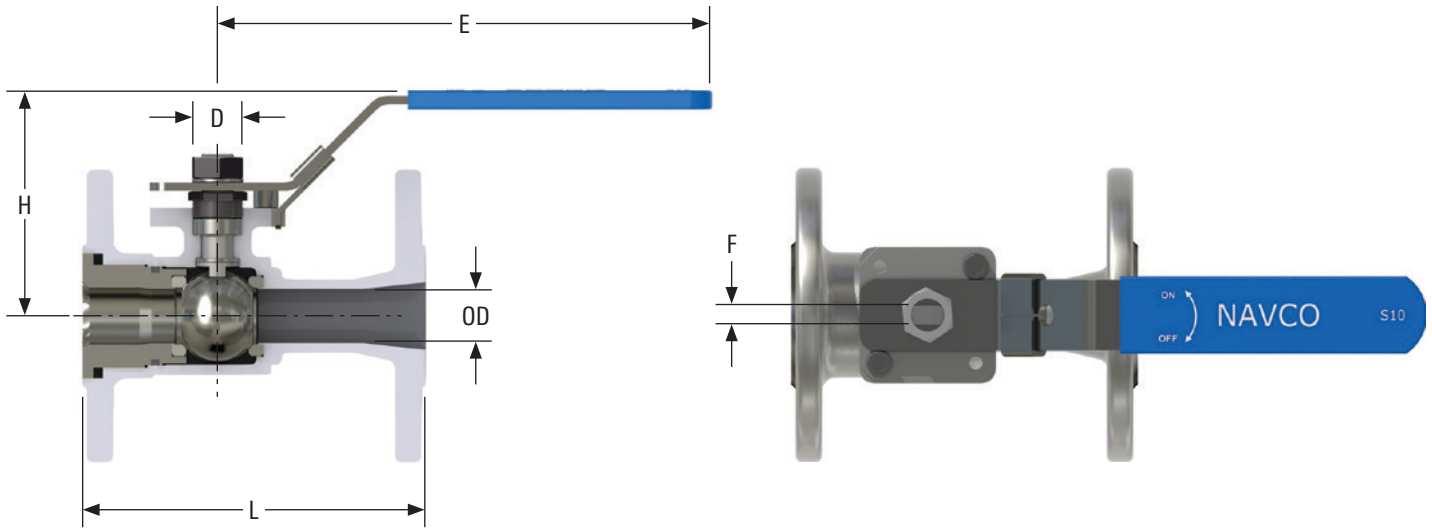

ASME Class 150 Dimensions

Size, in [mm]	OD, in [mm]	L, in [mm]	E, in [mm]	H, in [mm]	D	F, mm	ISO Pad	C _v	Torque, in.lbf [N.m]
½ [12.7]	0.49 [12.5]	4.25 [108]	5.50 [140]	2.9 [73]	M8 × 1.25	5	F04/M5	9	62 [7]
¾ [19.1]	0.59 [15]	4.60 [117]	5.50 [140]	3.0 [76]	M8 × 1.25	5	F04/M5	19	106 [12]
1 [25.4]	0.79 [20]	5.00 [127]	7.00 [180]	3.4 [86]	M12 × 1.75	7	F05/M6	45	160 [18]
1½ [38.1]	1.00 [25.4]	6.50 [165]	7.87 [200]	4.7 [119]	M14 × 2	9	F07/M8	125	265 [30]
2 [50.8]	1.50 [38]	7.00 [178]	9.00 [230]	5.0 [127]	M16 × 2	10	F07/M8	165	354 [40]
3 [76.2]	2.56 [65]	8.00 [203]	12.80 [325]	6.5 [164]	M22 × 2.5	15	F10/M10	350	708 [80]
4 [101.6]	3.00 [76]	9.00 [230]	12.80 [325]	7.0 [178]	M22 × 2.5	15	F10/M10	550	867 [98]
6 [152.4]	4.00 [102]	15.50 [394]	13.78 [350]	10.4 [264]	27.5	17	F10/M10	765	973 [110]

ASME Class 300 Dimensions

Size, in [mm]	OD, in [mm]	L, in [mm]	E, in [mm]	H, in [mm]	D	F, mm	ISO Pad	C _v	Torque, in.lbf [N.m]
½ [12.7]	0.49 [12.5]	5.50 [140]	5.50 [140]	2.9 [73]	M8 × 1.25	5	F04/M5	9	71 [8]
¾ [19.1]	0.59 [15]	6.00 [152]	5.50 [140]	3.0 [76]	M8 × 1.25	5	F04/M5	19	133 [15]
1 [25.4]	0.79 [20]	6.50 [165]	7.00 [180]	3.4 [86]	M12 × 1.75	7	F05/M6	45	177 [20]
1½ [38.1]	1.00 [25.4]	7.50 [190]	7.87 [200]	4.7 [119]	M14 × 2	9	F07/M8	125	310 [35]
2 [50.8]	1.50 [38]	8.50 [216]	9.00 [230]	5.0 [127]	M16 × 2	10	F07/M8	165	398 [45]
3 [76.2]	2.56 [65]	11.00 [283]	12.80 [325]	6.5 [164]	M22 × 2.5	15	F10/M10	350	814 [92]
4 [101.6]	3.00 [76]	12.00 [305]	12.80 [325]	7.0 [178]	M22 × 2.5	15	F10/M10	550	973 [110]
6 [152.4]	3.94 [100]	15.87 [403]	13.78 [350]	7.5 [190]	27.5	17	F10/M10	765	1,106 [125]

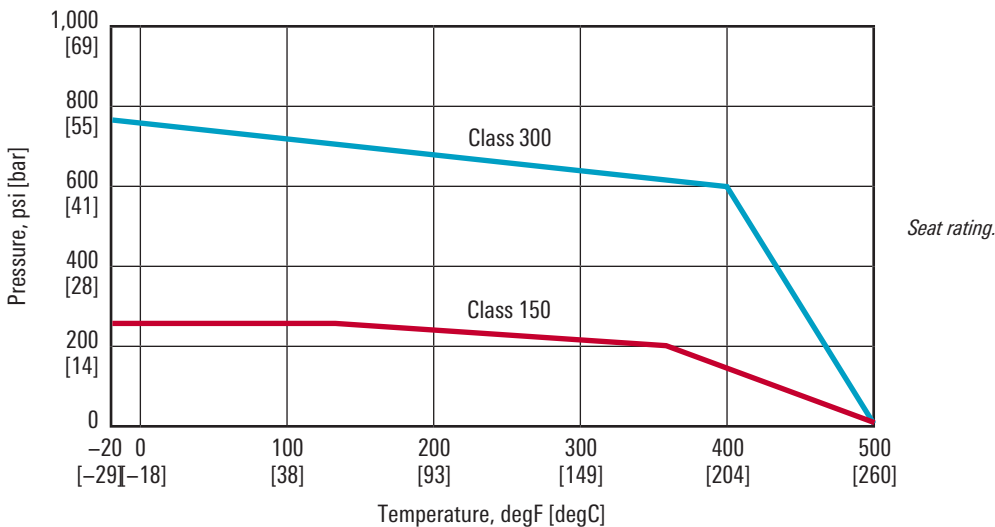

NAVCO S20 Floating Ball Valve

Two-piece threaded-end ball valves

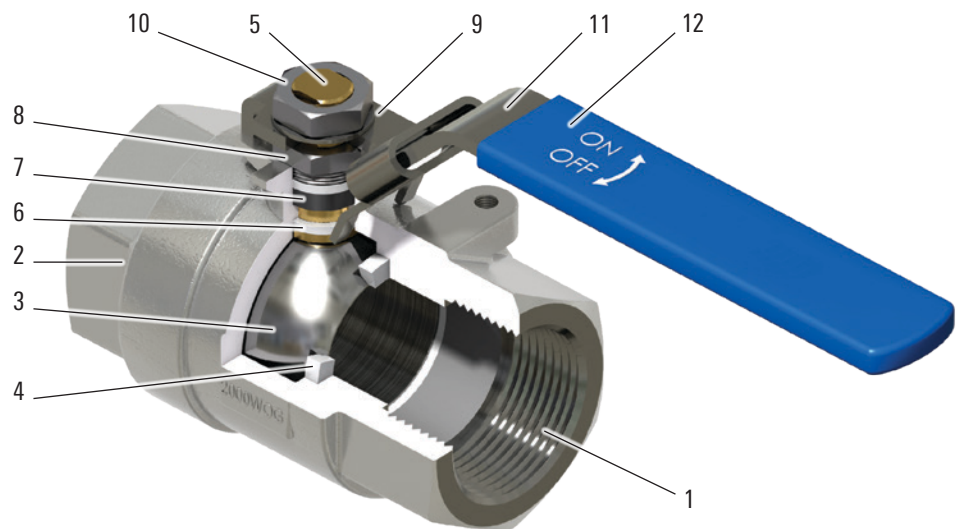

Features and benefits

- Two-piece threaded-end ball valve, full port, 2,000-psi WOG pressure
- Seal welding in full stainless version
- Investment cast body
- Fire testing and certification to API 607 5th Edition
- Working pressure: 2,000 psi
- Conformance to NACE MR0175 (2002) specifications
- Positively retained stem design
- Handle locking device

Materials List

Item	Quantity	Part	Material
1	1	Body	WCB or CF8M
2	1	Cap	WCB or CF8M
3	1	Ball	AISI 316
4	2	Seat	RPTFE
5	1	Stem	AISI 316
6	2	Stem seal	RPTFE
7	1	Stem packing	Graphite
8	1	Packing nut gland	AISI 304
9	1	Lock washer	AISI 304
10	1	Nut	A2-70
11	1	Handle	SS 201
12	1	Handle sleeve	Vinyl

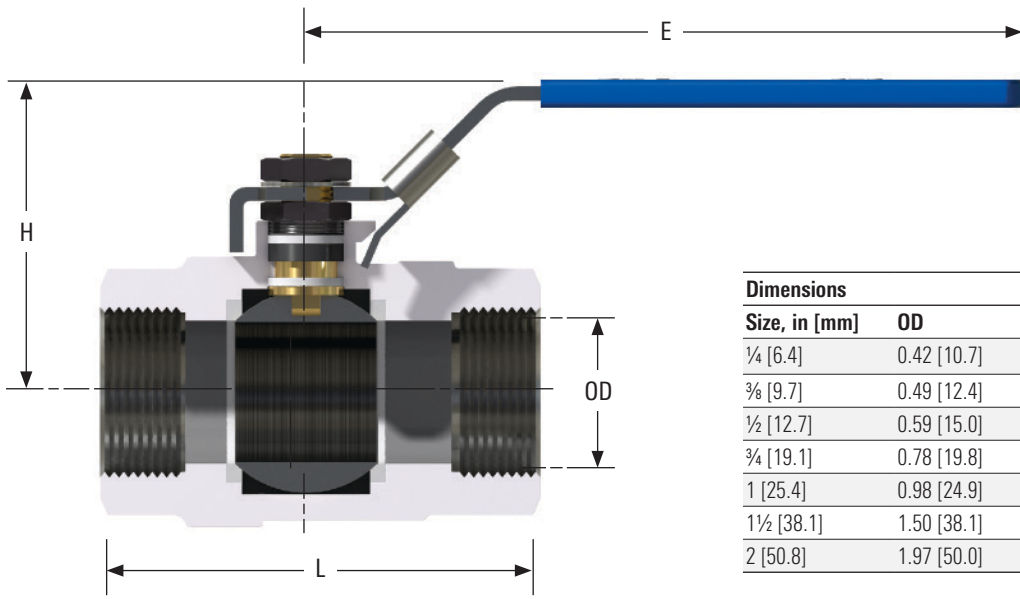

Dimensions

Size, in [mm]	OD	L	E	H
¼ [6.4]	0.42 [10.7]	2.36 [59.9]	3.93 [99.8]	1.89 [48.1]
⅜ [9.7]	0.49 [12.4]	2.36 [59.9]	3.93 [99.8]	1.89 [48.1]
½ [12.7]	0.59 [15.0]	2.95 [74.9]	4.33 [110.0]	2.28 [57.9]
¾ [19.1]	0.78 [19.8]	3.15 [80.0]	4.72 [119.9]	2.36 [59.9]
1 [25.4]	0.98 [24.9]	3.54 [89.9]	5.90 [149.9]	3.03 [77.0]
1½ [38.1]	1.50 [38.1]	4.72 [119.9]	7.08 [179.8]	3.62 [92.0]
2 [50.8]	1.97 [50.0]	5.51 [140.0]	7.08 [179.8]	4.13 [104.9]

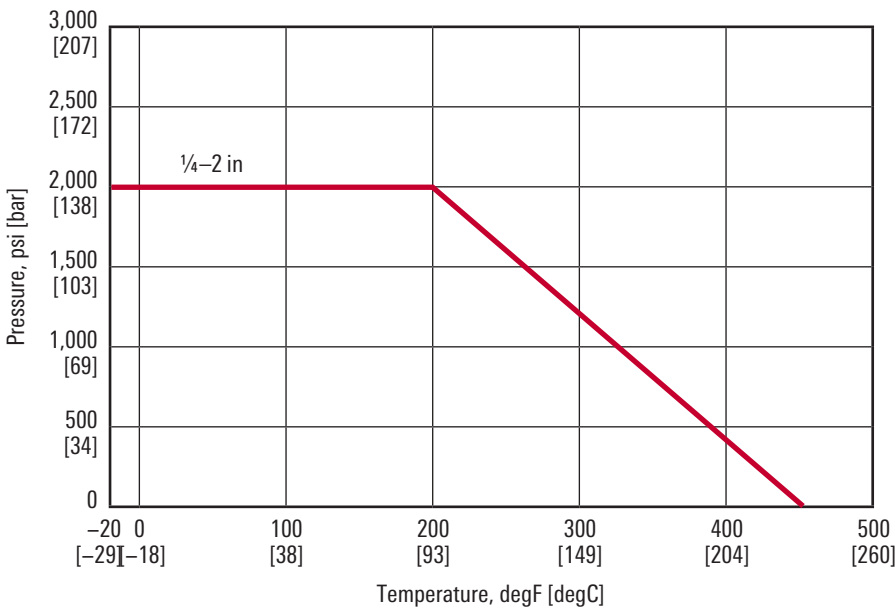
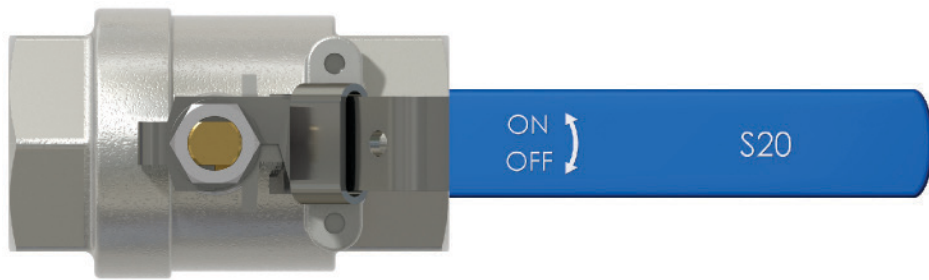

Seat rating.

NAVCO S30 Ball Valve

Three-piece, threaded-end economy ball valves, fire tested and inline repairable

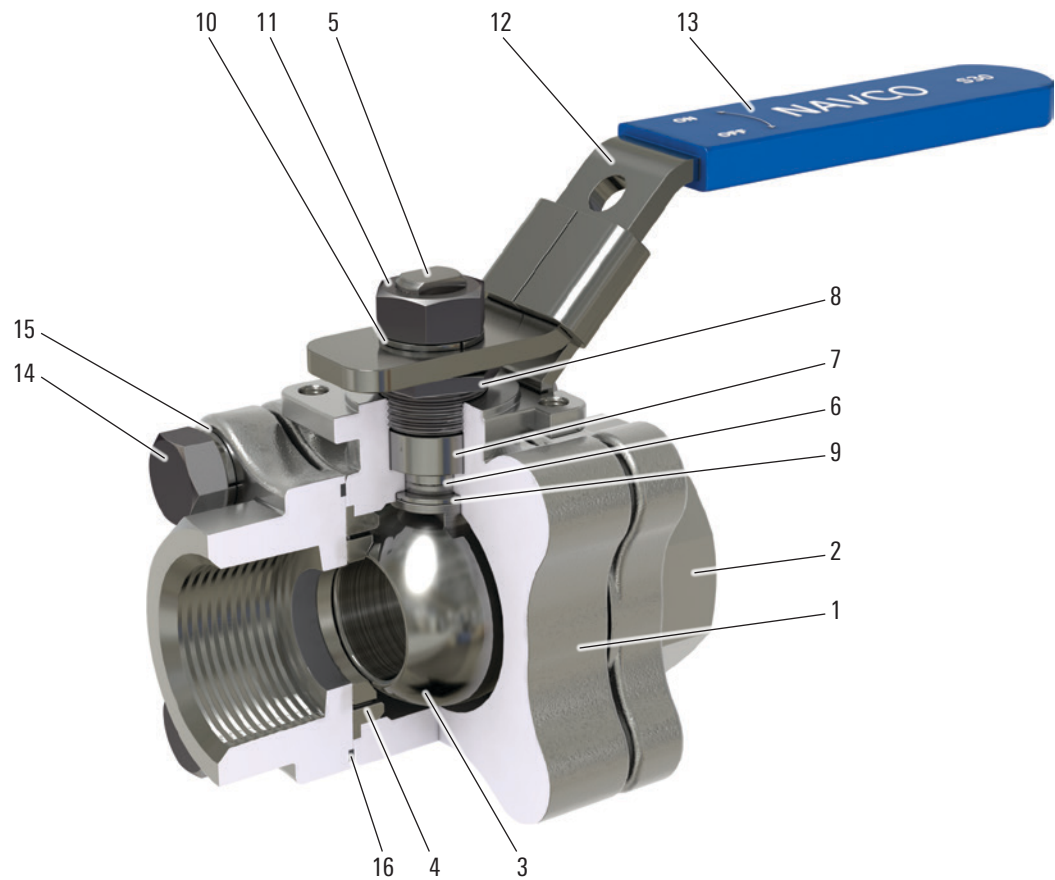

Features and benefits

- Three-piece full-port threaded-end ball valve
 - ½ to 1 in: 2,000-psi MOP
 - 1¼ to 2 in: 1,500-psi MOP
- Investment cast body
- Fire testing and certification to API 607 5th Edition
- Conformance to NACE/ISO 15156 specifications
- Positively retained stem design
- Handle locking device
- ASME B16.34
- ISO mounting pad
- Availability in carbon steel–stainless steel and stainless steel–stainless steel
- Swing-out body for inline repair
- Optional locking oval handle
- Available socket weld end option

Materials List

Item	Quantity	Part	Material
1	1	Body	WCB/CF8M
2	2	Cap	WCB/CF8M
3	1	Ball	CF8M
4	2	Seat	TFM
5	1	Stem	AISI 316
6	1	Stem seal	PTFE
7	1	Stem packing	Graphite
8	1	Gland	AISI 304
9	1	Thrust washer	PTFE
10	1	Washer	SS
11	1	Nut	A2-70
12	1	Handle	AISI 304
13	1	Handle sleeve	PVC
14	8	Bolt	A2-70
15	8	Lock washer	SS
16	2	Body seal	Graphite

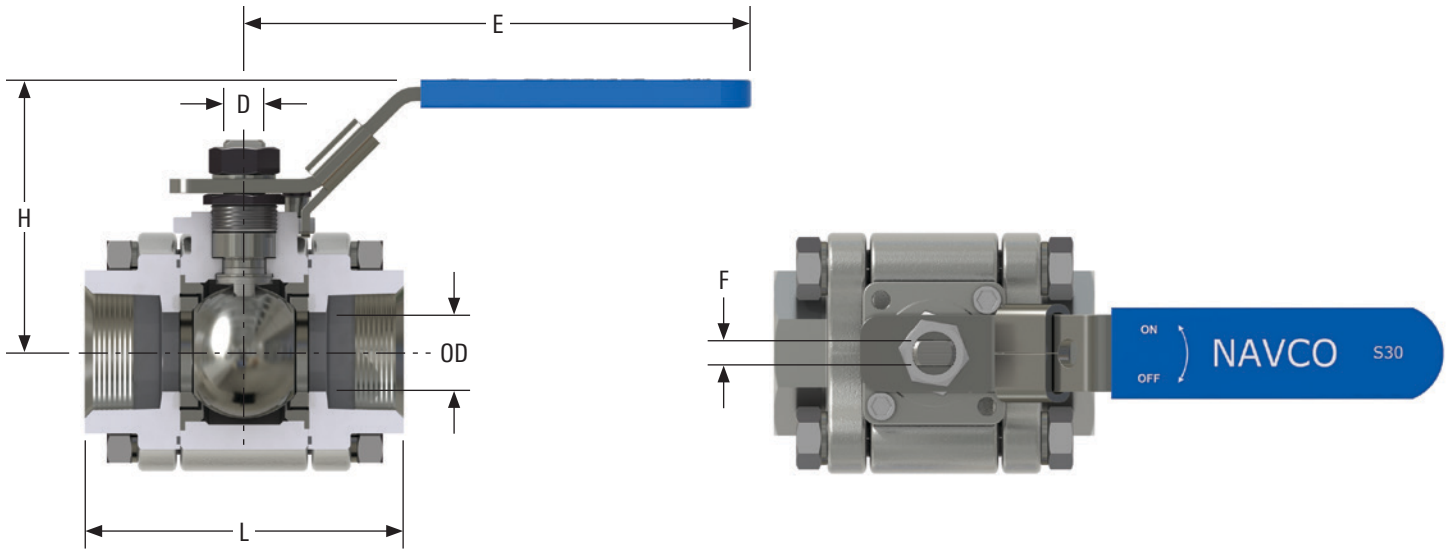

Dimensions

Size, in [mm]	OD, in [mm]	L, in [mm]	E, in [mm]	H, in [mm]	D	F, mm	ISO Pad	C _v	Torque, in.lbf [N.m]
½ [12.7]	0.59 [15]	3.0 [75]	4.5 [115]	2.3 [58]	M10 × 1.5	6	F04/M5	24	133 [15]
¾ [19.1]	0.79 [20]	3.1 [80]	5.9 [150]	2.6 [65]	M12 × 1.75	7	F04/M5	55	177 [20]
1 [25.4]	0.98 [25]	3.5 [90]	5.9 [150]	2.9 [75]	M12 × 1.75	7	F04/M5	100	265 [30]
1¼ [31.8]	1.26 [32]	4.3 [110]	7.5 [190]	3.5 [90]	M14 × 2	9	F05/M6	160	300 [34]
1½ [38.1]	1.50 [38]	4.7 [120]	9.0 [230]	3.8 [96]	M16 × 2	10	F05/M6	260	336 [38]
2 [50.8]	1.97 [50]	5.5 [140]	9.0 [230]	4.1 [105]	M16 × 2	10	F05/M6	450	442 [50]

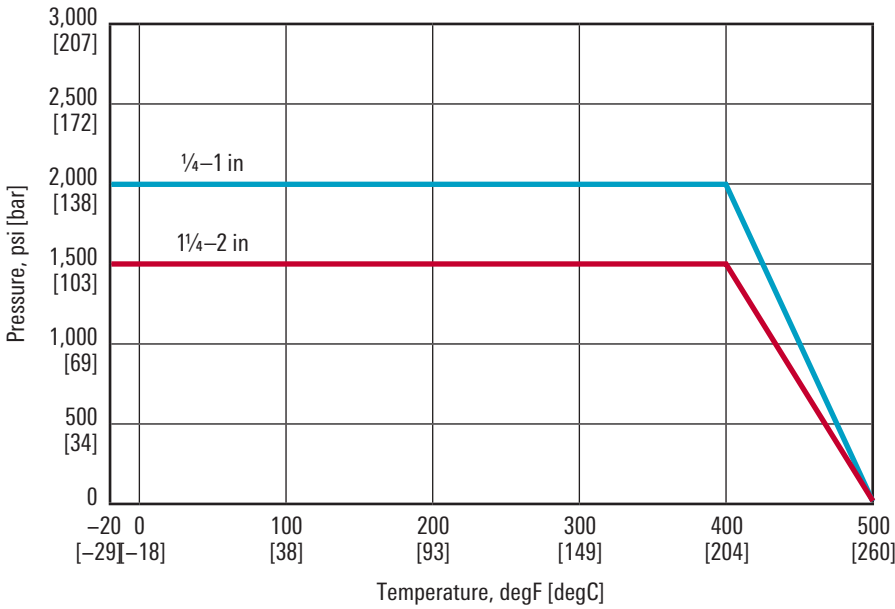

Seat rating.

NAVCO Needle and Gauge Valves

Needle valves

Soft-seated,
6,000-psi valve.

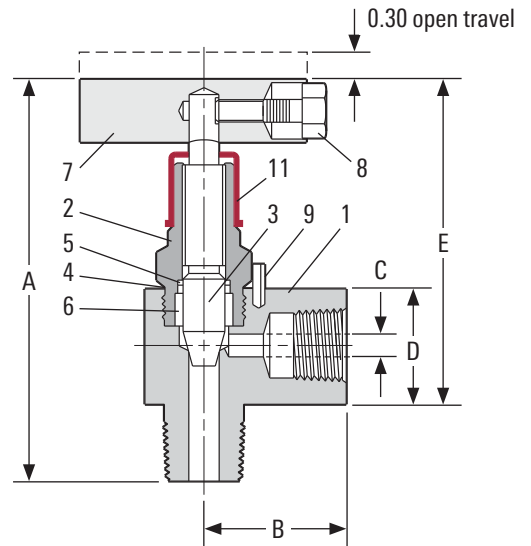
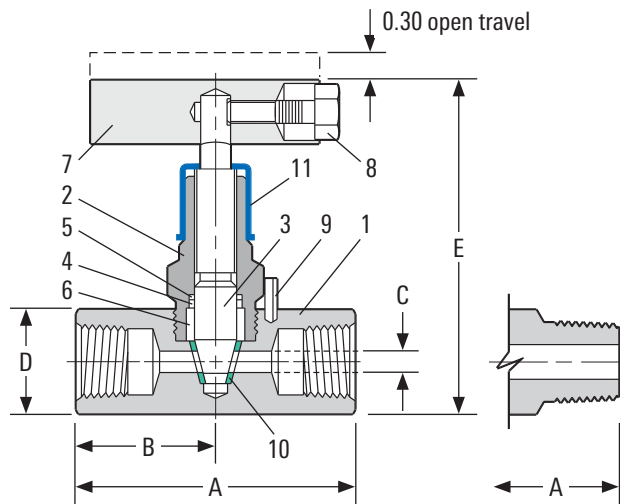

Metal-seated angle valve.

Metal-seated,
10,000-psi valve.

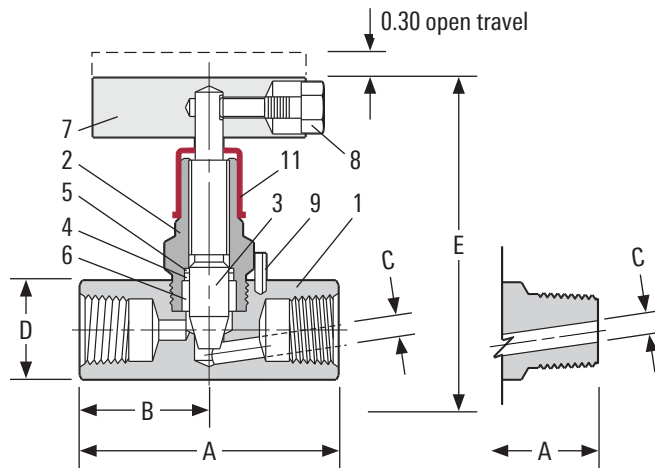

Part Number		Size, in [mm]	Working Pressure, psi	Body Style		Dimensions, in					Weight, lbm
CS Body	SS Body			M × F	F × F	A	B	C	D	E	
42V-145	42VN-145	¼ [6]	6,000	•	–	3.25	1.44	0.25	1.13	3.56	1.50
42V-125	42VN-125	½ [15]	6,000	•	–	3.38	1.44	0.25	1.13	3.56	1.50
42V-14	42VN-14	¼ [6]	6,000	–	•	2.88	1.44	0.25	1.13	3.56	1.25
42V-12	42VN-12	½ [15]	6,000	–	•	2.88	1.44	0.25	1.13	3.56	1.25
41V-145	41VN-145	¼ [6]	10,000	•	–	3.25	1.44	0.25	1.13	3.50	1.50
41V-125	41VN-125	½ [15]	10,000	•	–	3.38	1.44	0.25	1.13	3.50	1.50
41V-14	41VN-14	¼ [6]	10,000	–	•	2.88	1.44	0.25	1.13	3.50	1.25
41V-12	41VN-12	½ [15]	10,000	–	•	2.88	1.44	0.25	1.13	3.50	1.25
41V-145A	41VN-145A	¼ [6]	10,000	•	–	4.34	1.50	0.25	1.25	3.50	1.25
41V-125A	41VN-125A	½ [15]	10,000	•	–	4.34	1.50	0.25	1.25	3.50	1.25

Item	Quantity	Part	Soft Seat		Metal Seat	
			CS	SS	CS	SS
1	1	Body	A105	316 SS	A105	316 SS
2	1	Bonnet	A105	316 SS	A105	316 SS
3	1	Stem	316 SS	316 SS	316 SS	316 SS
4	1	Stem seal	Viton material O-ring	Viton material O-ring	Viton material O-ring	Viton material O-ring
5	1	Backup ring	Viton material	Viton material	Viton material	Viton material
6	1	Sleeve	A105	316 SS	A105	316 SS
7	1	Handle	CS	316 SS	CS	316 SS
8	1	Capscrew	CS	316 SS	CS	316 SS
9	1	Lock pin	Spring steel	Spring steel	Spring steel	Spring steel
10	1	Seat	Nylon	Nylon	–	–
11	1	Boot	Blue	Blue	Red	Red

Gauge valves

Standard features

- Oversized barstock body
- Precision-threaded bonnet
- Bonnet lock pin
- Backseat stem design
- Viton material O-ring stem seal
- Metal-to-metal stem sealing
- Soft seat or metal seat options
- Large T-handle
- ASME B1.20.1 threads
- NACE MR0175 trim option
- Color-coded stem boot

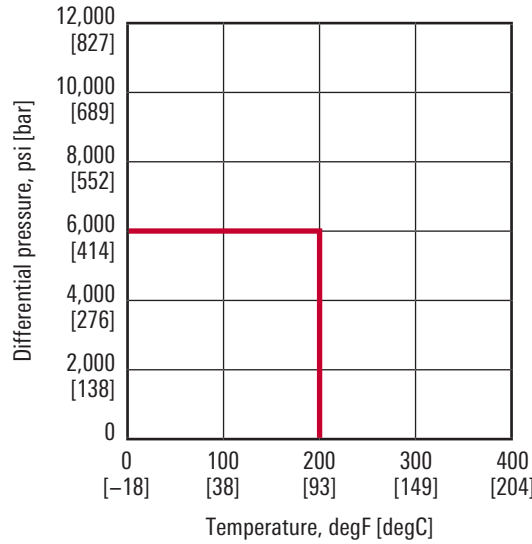

Soft-seated, 6,000-psi needle and gauge valves with nylon seat and Viton material stem seal.

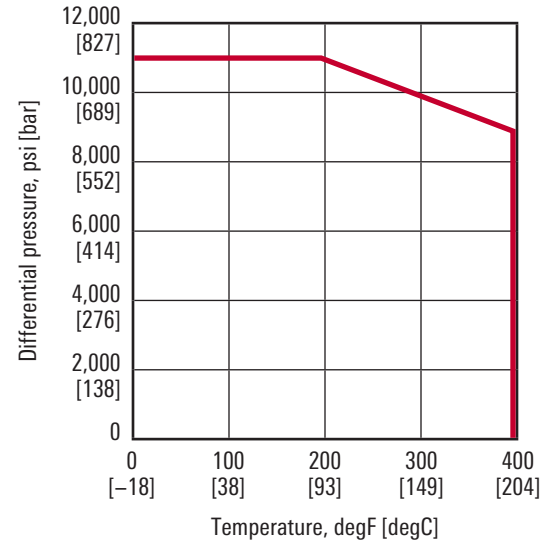

Soft-seated, 6,000-psi needle and gauge valves with Viton material stem seal.

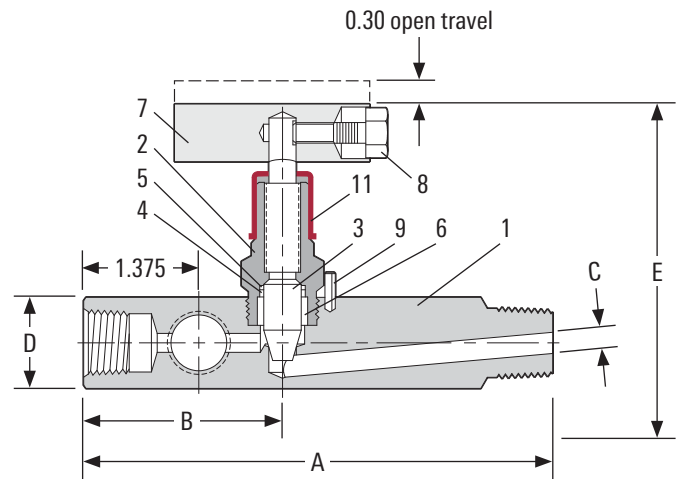
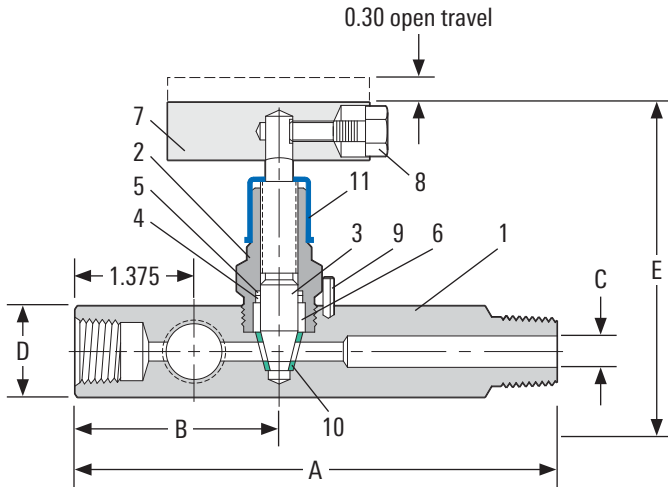

Part Number		Size, in [mm]	Working Pressure, psi	Body Style		Dimensions, in					Weight, lbm
CS Body	SS Body			M × F	Long Body	A	B	C	D	E	
44V-125	44VN-125	½ [15]	6,000	•	–	5.63	2.38	0.25	1.13	3.56	2.25
44V-125L	44VN-125L	½ [15]	6,000	•	•	7.25	2.38	0.25	1.13	3.56	2.50
44V-12345	44VN-12345	½ × ¾ [15 × 20]	6,000	•	–	5.63	2.38	0.25	1.13	3.56	2.50
43V-125	43VN-125	½ [15]	10,000	•	–	5.63	2.38	0.25	1.13	3.50	2.25

Item	Quantity	Part	Soft Seat		Metal Seat	
			CS	SS	CS	SS
1	1	Body	A105	316 SS	A105	316 SS
2	1	Bonnet	A105	316 SS	A105	316 SS
3	1	Stem	316 SS	316 SS	316 SS	316 SS
4	1	Stem seal	Viton material O-ring	Viton material O-ring	Viton material O-ring	Viton material O-ring
5	1	Backup ring	Viton material	Viton material	Viton material	Viton material
6	1	Sleeve	A105	316 SS	A105	316 SS
7	1	Handle	CS	316 SS	CS	316 SS
8	1	Capscrew	CS	316 SS	CS	316 SS
9	1	Lock pin	Spring steel	Spring steel	Spring steel	Spring steel
10	1	Seat	Nylon	Nylon	–	–
11	1	Boot	Blue	Blue	Red	Red

NAVCO Floating Ball Valves

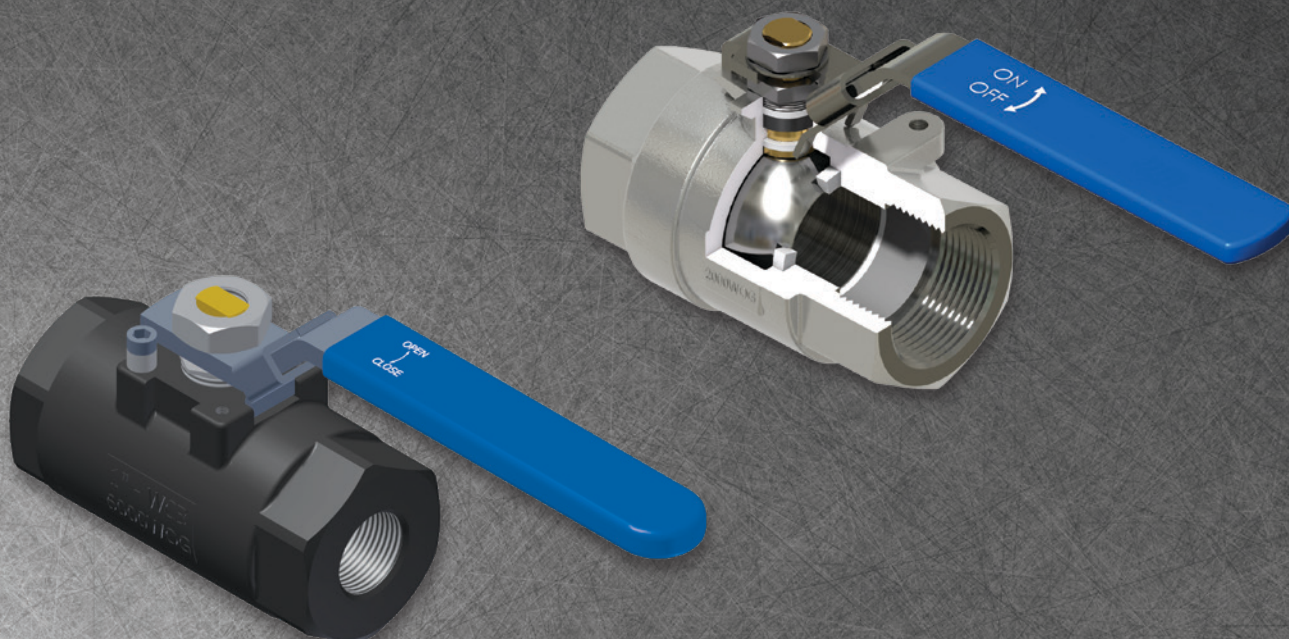

cameron.slb.com/navco

NAVCO is a mark of Schlumberger.
Other company, product, and service names
are the properties of their respective owners.
Copyright © 2017 Schlumberger. All rights reserved. 16-VL-228527

 **CAMERON**
A Schlumberger Company