

# Constrictor Multi Line Ram Seal and Q-GUIDE™ Rams



The Elmar Q-GUIDE™ ram is a proprietary patented design that provides a positive alignment for the wireline. V-shaped flat guides on either side of the inner seal restrict the wireline so that the section of line contacting the inner seal is always centred and parallel to the wireline valve axis.



Q-GUIDE™ Ram Assembly  
(Patented design)

The Q-GUIDE™ has been designed to accommodate eccentric set-ups where the wireline goes through the wireline valve body at an angle and can be trapped by the rams before falling in the cable groove.

The Q-GUIDE™ style of ram has been developed to replace integral guide style rams. Inner and outer seals used in the Q-GUIDE™ are the same as used in the current styles of ram bodies.

The Elmar Constrictor multi-line inner seal can be used with the Q-GUIDE™ ram for maximum effect.

The Q-GUIDE™ is available for all sizes of wireline valves.

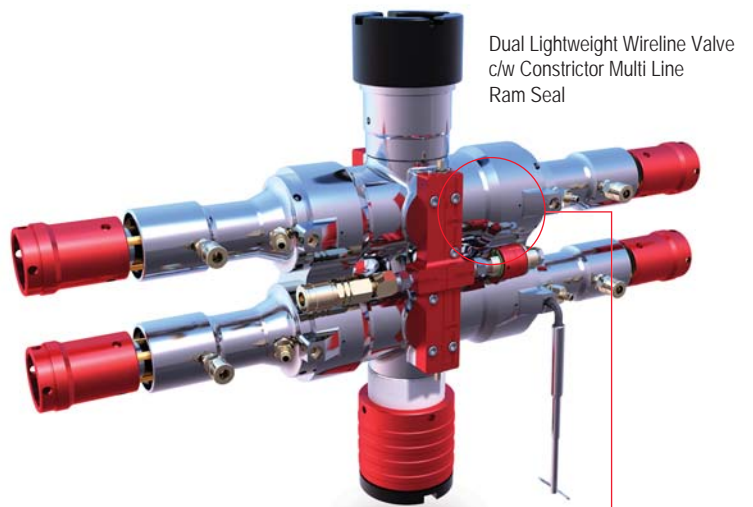

Dual Lightweight Wireline Valve  
c/w Constrictor Multi Line  
Ram Seal

## RAM ASSEMBLY PART NUMBER

BOP Size	New Part Number	Coding
3"	L-9701042661	* *
4 - 4.5"	L-9701042660	* *
5 - 5.5"	L-9701042659	* *
6 - 6.5"	L-9701042502	* *
9"	L-9701042231	* *

## Ordering Information

### ELASTOMER

H	HYD NITRILE
M	MULTI

### MULTILINE RANGE - HYD NITRILE

1	Blind - 5/16"
2	5/16" - 15/32"

## LINE SIZE

125	188	218	250	281	312	375	438	468
1/8"	3/16"	7/32"	1/4"	9/32"	5/16"	3/8"	7/16"	15/32"

Note: Additional line sizes available on request.

Ordering Example: L-9701972667M312 - 3" Q-GUIDE™ ram assembly dressed with multilines seals for Blind through to 5/16" wireline.  
L-9701972667H312 - 3" Q-GUIDE™ ram assembly dressed with HNBR seals for 5/16" wireline.

The Constrictor (Patent pending)  
Multiline Ram Seal

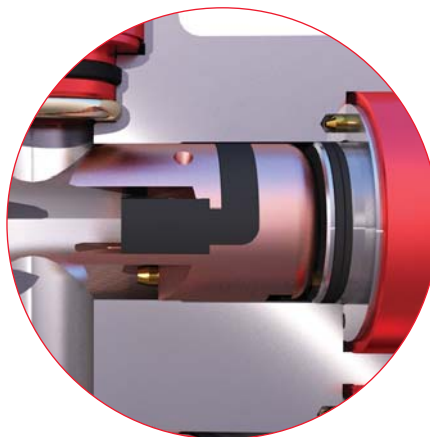

Multi Line Ram Seal